



ProLight Opto Technology Corporation

ProLight STAR/O with PG1C-3LxE-SD

Technical Datasheet

Version: 1.2

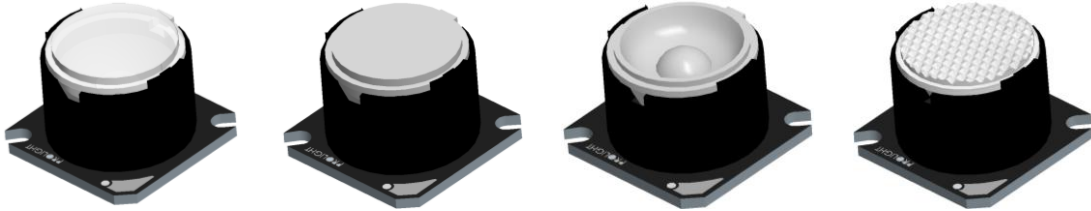

Features

- High Flux per LED
- Various colors
- Good color uniformity
- More energy efficient than incandescent and most halogen lamps
- Low Voltage DC operated
- Instant light (less than 100ns)
- No UV
- Superior ESD protection

Typical Applications

- Reading lights (car, bus, aircraft)
- Portable (flashlight, bicycle)
- Uplighters/Downlighters
- Decorative/Entertainment
- Bollards/Security/Garden
- Cove/Undershelf/Task
- Indoor/Outdoor Commercial and Residential Architectural
- Automotive Ext (Stop-Tail-Turn, CHMSL, Mirror Side Repeat)

Table of Contents

- Part Number List
 - Mechanical Dimensions
 - Flux Characteristics of LED
 - Electrical Characteristics of Module
 - Optical Characteristics of Module
 - Absolute Maximum Ratings
 - Photometric Luminous Flux Bin Structure of LE
 - Color Bin
 - Dominant Wavelength Bin Structure
 - Color Spectrum
 - Light Output Characteristics
 - Forward Current Characteristics
 - Ambient Temperature vs. Maximum Forward Current
 - Typical Representative Spatial Radiation Patte
-

Part Number List

Part Number	Description	LED module	MCPCB	Collimator P/N	Holder P/N
PG1C-3LxC-SD	PG1C-3LxE-SD Star/O 15°		Square Type	PG1N-NX15	PG1N-SO02
PG1C-3LxG-SD	PG1C-3LxE-SD Star/O 25°	PG1C-3LxE-SD	Square Type	PG1N-NX23	PG1N-SO02
PG1C-3LxH-SD	PG1C-3LxE-SD Star/O 35°		Square Type	PG1C-NX36	PG1N-SO01
PG1C-3LxD-SD	PG1C-3LxE-SD Star/O 45°		Square Type	PG1N-NX43	PG1N-SO02

Mechanical Dimensions and Illuminance Chart

Part Number : PG1C-3LxC-SD

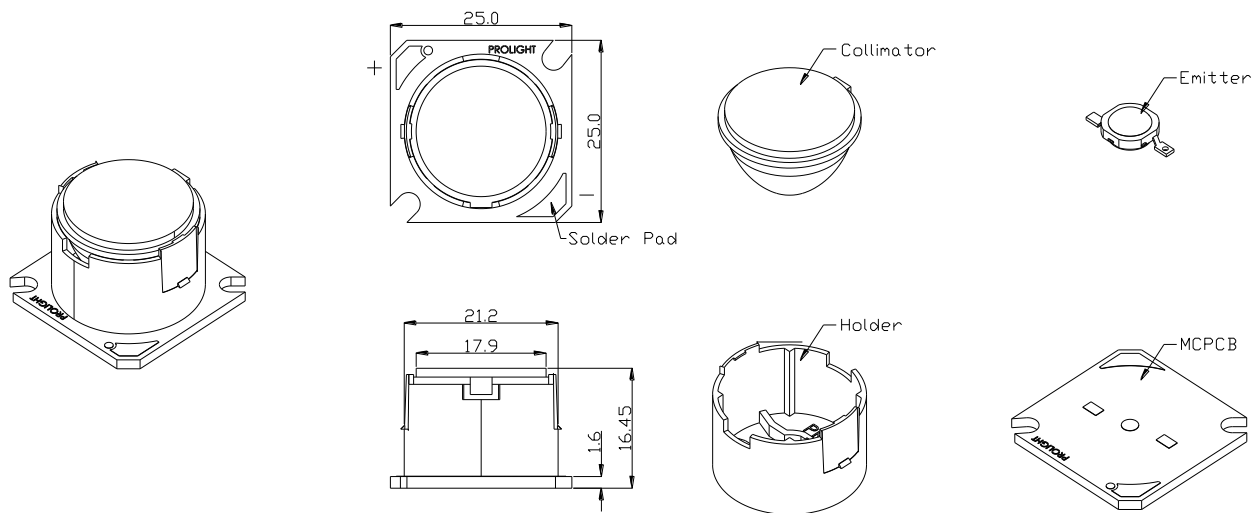
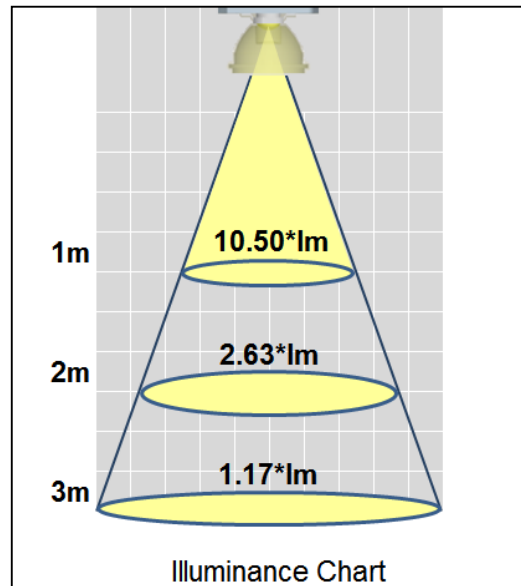

Notes:

1. Slots in aluminum-core PCB for M3 or #4 mounting screw.
2. Electrical interconnection pads labeled on the aluminum-core PCB with "+" and "-" to denote positive and negative, respectively. All positive pads are interconnected, as are all negative pads, allowing for flexibility in array interconnection.
3. Drawing not to scale.
4. All dimensions are in millimeters.

*The appearance and specifications of the product may be modified for improvement without notice.

Mechanical Dimensions and Illuminance Chart

Part Number : PG1C-3LxG-SD

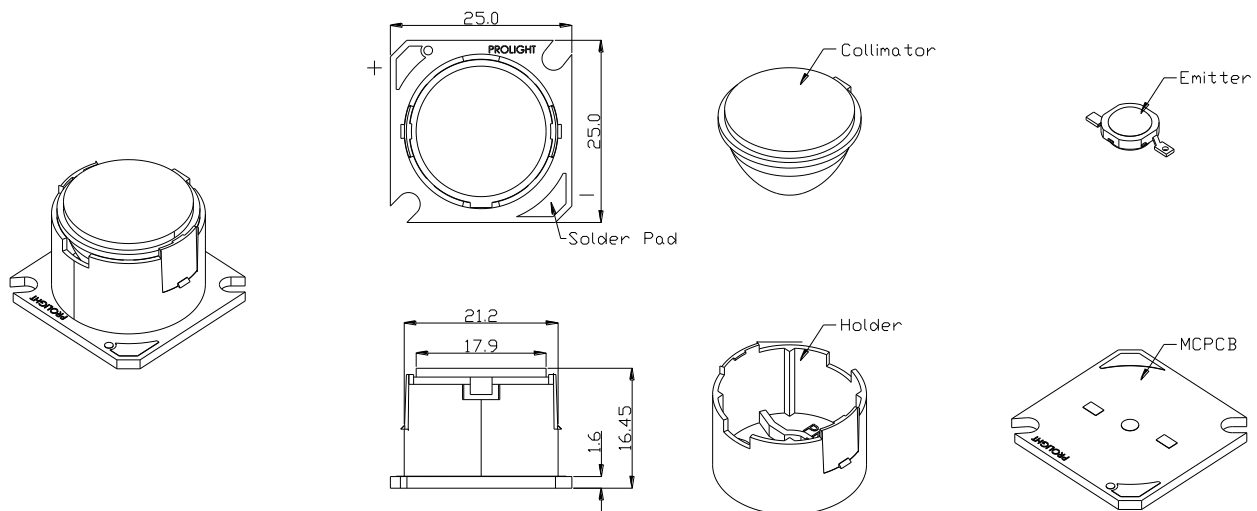
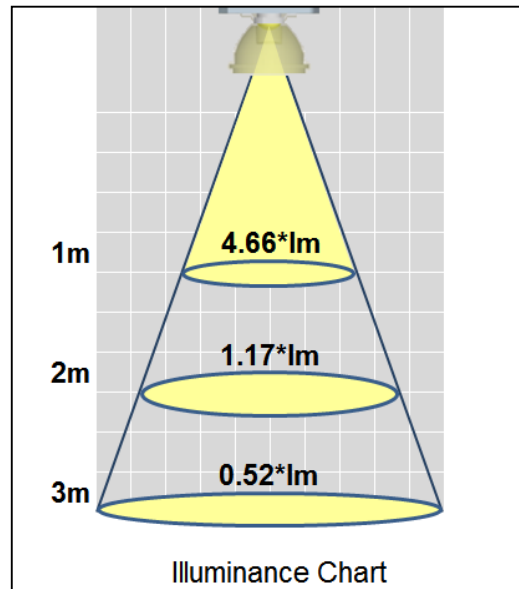

Notes:

1. Slots in aluminum-core PCB for M3 or #4 mounting screw.
2. Electrical interconnection pads labeled on the aluminum-core PCB with "+" and "-" to denote positive and negative, respectively. All positive pads are interconnected, as are all negative pads, allowing for flexibility in array interconnection.
3. Drawing not to scale.
4. All dimensions are in millimeters.

*The appearance and specifications of the product may be modified for improvement without notice.

Mechanical Dimensions and Illuminance Chart

Part Number : PG1C-3LxH-SD

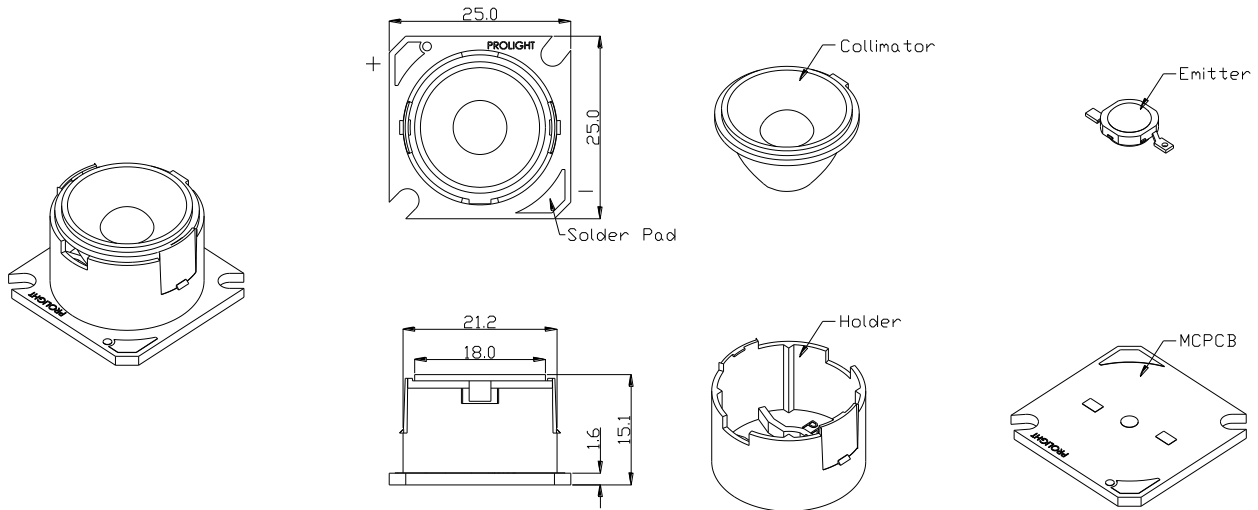
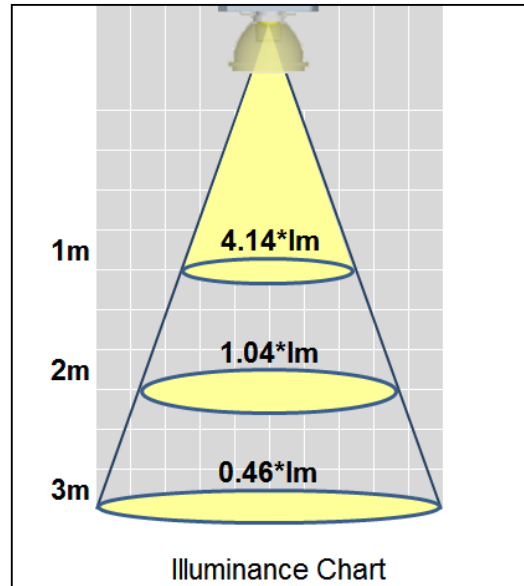

Notes:

1. Slots in aluminum-core PCB for M3 or #4 mounting screw.
2. Electrical interconnection pads labeled on the aluminum-core PCB with "+" and "-" to denote positive and negative, respectively. All positive pads are interconnected, as are all negative pads, allowing for flexibility in array interconnection.
3. Drawing not to scale.
4. All dimensions are in millimeters.

*The appearance and specifications of the product may be modified for improvement without notice.

Mechanical Dimensions and Illuminance Chart

Part Number : PG1C-3LxD-SD

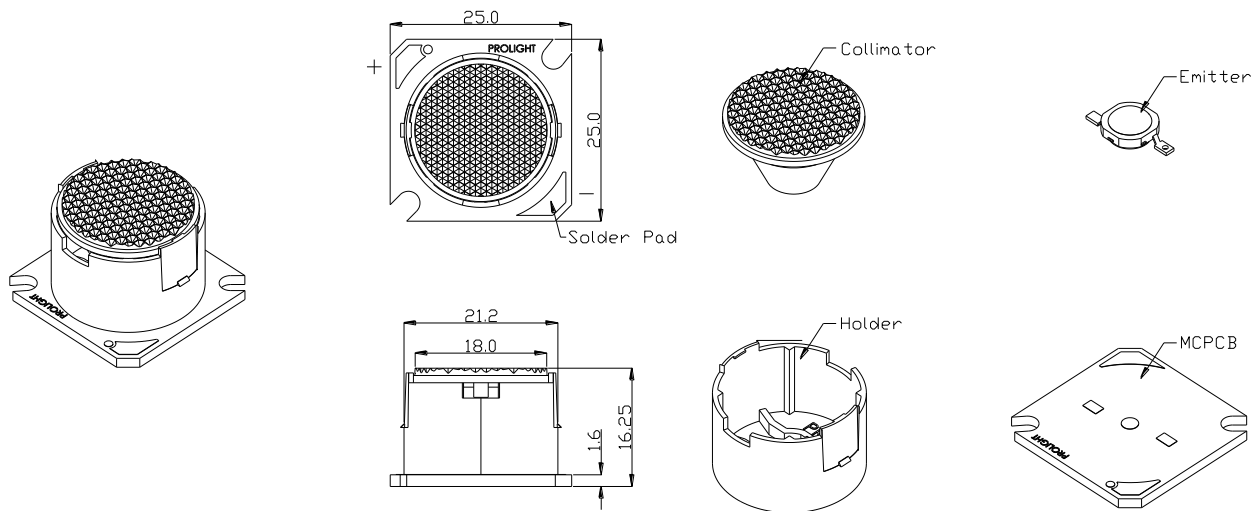
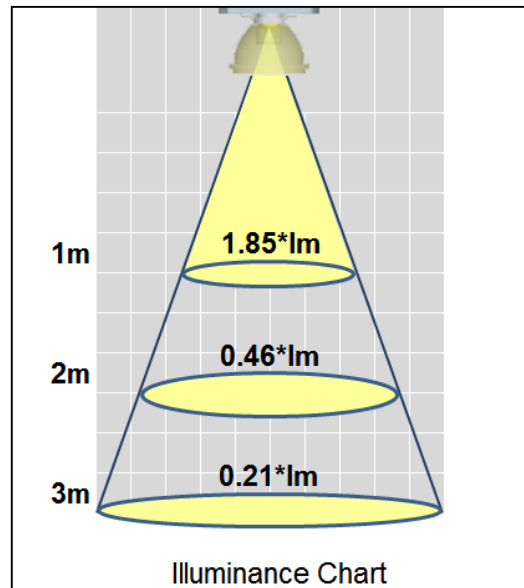

Notes:

1. Slots in aluminum-core PCB for M3 or #4 mounting screw.
2. Electrical interconnection pads labeled on the aluminum-core PCB with "+" and "-" to denote positive and negative, respectively. All positive pads are interconnected, as are all negative pads, allowing for flexibility in array interconnection.
3. Drawing not to scale.
4. All dimensions are in millimeters.

*The appearance and specifications of the product may be modified for improvement without notice.

Flux Characteristics of LED at 700mA, T_J = 25°C

Radiation Pattern	Color	Part Number Module	LumiousFlux or Power	
			Minimum	Typical
Lambertian	White	PG1C-3LWx-SD	129.5	148
	Warm White	PG1C-3LVx-SD	113.6	138
	Red	PG1C-3LRx-SD	58.9	81
	Amber	PG1C-3LAX-SD	67.2	85
	Green	PG1C-3LGx-SD	99.6	114
	Blue	PG1C-3LBx-SD	23.5	32

- ProLight maintains a tolerance of ± 10% on flux and power measurements.
- Please do not drive at rated current more than 1 second without proper heat sink.

Electrical Characteristics of Module at 700mA, T_J = 25°C

Color	Forward Voltage V _F (V)			Thermal Resistance Junction to Board (°C/ W)
	Min.	Typ.	Max.	
White	3.1	3.8	4.35	13
Warm White	3.1	3.8	4.35	13
Red	2.0	2.7	3.25	15
Amber	2.0	2.7	3.25	15
Green	3.1	3.9	4.35	13
Blue	3.1	3.8	4.35	13

Optical Characteristics of Module at 700mA, T_J = 25°C

Color	Dominant Wavelength λ _D , or Color Temperature CCT			PG1C-3LxC-SD			PG1C-3LxG-SD			PG1C-3LxH-SD			PG1C-3LxD-SD		
	Min.	Typ.	Max.	VA	BA	X	VA	BA	X	VA	BA	X	VA	BA	X
	White	4100 K	5500 K	10000 K	15	10	38	20	15	17	30	20	15	40	25
Warm White	2700 K	3300 K	4100 K	15	10	38	20	15	17	30	20	15	40	25	6
Green	515 nm	525 nm	535 nm	15	10	55	20	15	22	30	20	17	40	25	6
Blue	455 nm	465 nm	475 nm	15	10	55	20	15	22	30	20	17	40	25	6
Amber	587 nm	592 nm	597 nm	15	10	55	20	15	22	30	20	17	40	25	6
Red	613.5 nm	623 nm	631 nm	15	10	55	20	15	22	30	20	17	40	25	6

- ProLight maintains a tolerance of ± 1nm for dominant wavelength measurements.
- ProLight maintains a tolerance of ± 5% for CCT measurements.

Absolute Maximum Ratings

Parameter	White/Warm White/ Red/Amber/Green/Blue
DC Forward Current (mA)	700
Peak Pulsed Forward Current (mA)	1000
Average Forward Current (mA)	700
ESD Sensitivity (HBM per MIL-STD-883E Method 3015.7)	±4000V (Class III)
LED Junction Temperature (°C)	120
Aluminum-core PCB Temperature (°C)	75
Storage & Operating Temperature (°C)	-40 to +75

Photometric Luminous Flux Bin Structure

Color	Bin Code	Minimum Photometric Flux (lm)	Maximum Photometric Flux (lm)	Available Color Bins
White	V2	129.5	147.7	All
	W1	147.7	168.4	Yx, Xx, Wx, Vx, Ux ^[1]
Warm White	V1	113.6	129.5	All
	V2	129.5	147.7	All
	W1	147.7	168.4	Sx, Rx ^[1]
Red	S2	58.9	67.2	All
	T1	67.2	76.6	All
	T2	76.6	87.4	All
	U1	87.4	99.6	[1]
Amber	T1	67.2	76.6	All
	T2	76.6	87.4	All
	U1	87.4	99.6	[1]
Green	U2	99.6	113.6	All
	V1	113.6	129.5	All
	V2	129.5	147.7	[1]
Blue	P	23.5	30.6	A, 1, 2 ^[1]
	Q	30.6	39.8	1, 2 ^[1]
	R	39.8	51.7	[1]

- ProLight maintains a tolerance of ± 10% on flux and power measurements.
- The flux bin of the product may be modified for improvement without notice.
- ^[1] The rest of color bins are not 100% ready for order currently. Please ask for quote and order possibility.

Color Bin

White and Warm White Binning Structure Graphical Representation

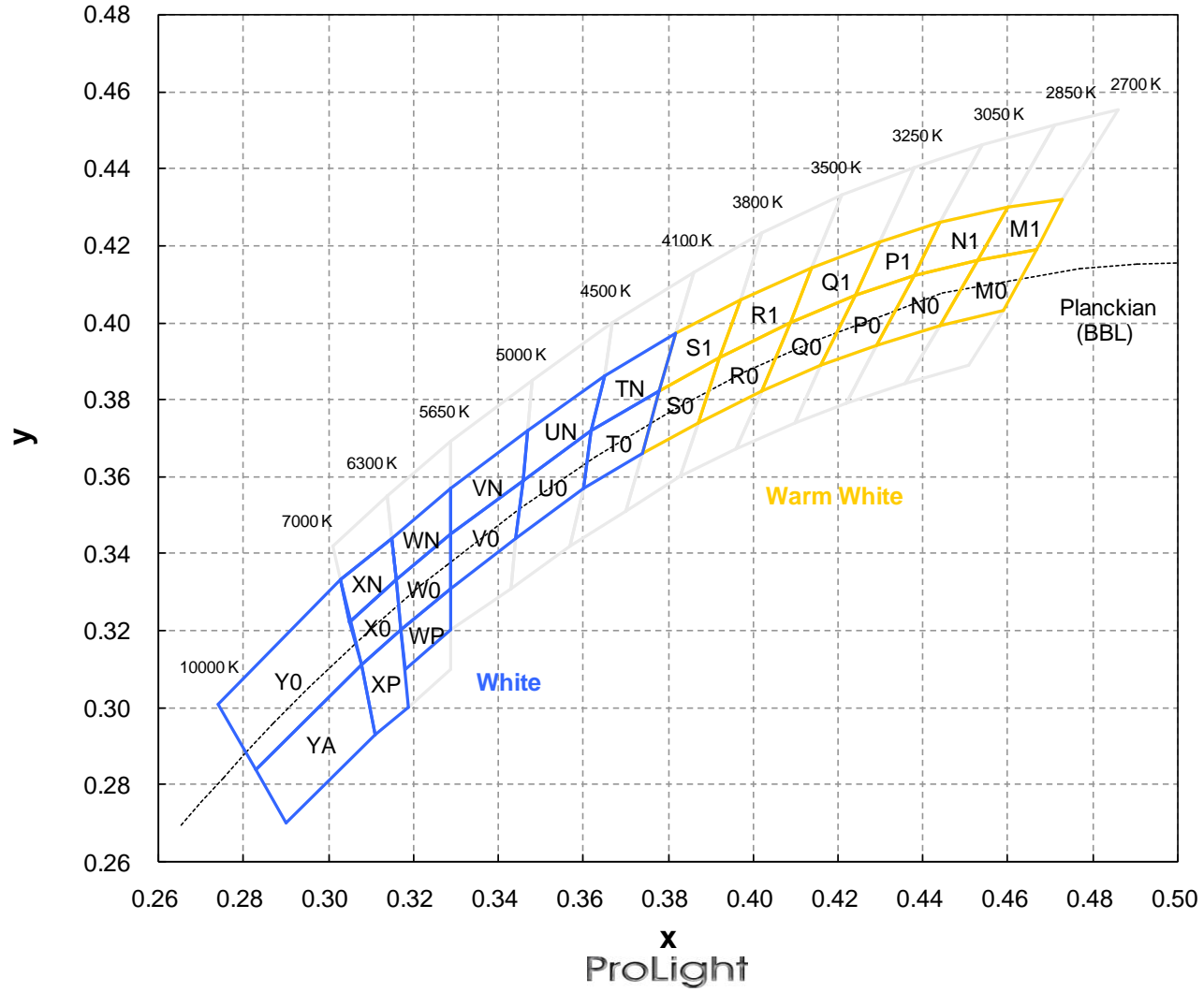

Color Bins

White Bin Structure

Bin Code	x	y	Typ. CCT (K)	Bin Code	x	y	Typ. CCT (K)
T0	0.378	0.382	4300	WN	0.329	0.345	5970
	0.374	0.366			0.316	0.333	
	0.360	0.357			0.315	0.344	
	0.362	0.372			0.329	0.357	
TN	0.382	0.397	4300	WP	0.329	0.331	5970
	0.378	0.382			0.329	0.320	
	0.362	0.372			0.318	0.310	
	0.365	0.386			0.317	0.320	
U0	0.362	0.372	4750	X0	0.308	0.311	6650
	0.360	0.357			0.305	0.322	
	0.344	0.344			0.316	0.333	
	0.346	0.359			0.317	0.320	
UN	0.365	0.386	4750	XN	0.305	0.322	6650
	0.362	0.372			0.303	0.333	
	0.346	0.359			0.315	0.344	
	0.347	0.372			0.316	0.333	
V0	0.329	0.331	5320	XP	0.308	0.311	6650
	0.329	0.345			0.317	0.320	
	0.346	0.359			0.319	0.300	
	0.344	0.344			0.311	0.293	
VN	0.329	0.345	5320	Y0	0.308	0.311	8000
	0.329	0.357			0.283	0.284	
	0.347	0.372			0.274	0.301	
	0.346	0.359			0.303	0.333	
W0	0.329	0.345	5970	YA	0.308	0.311	8000
	0.329	0.331			0.311	0.293	
	0.317	0.320			0.290	0.270	
	0.316	0.333			0.283	0.284	

- Tolerance on each color bin (x , y) is ± 0.01

Note: Although several bins are outlined, product availability in a particular bin varies by production run and by product performance. Not all bins are available in all colors.

Color Bins

Warm White Bin Structure

Bin Code	x	y	Typ. CCT (K)	Bin Code	x	y	Typ. CCT (K)
M0	0.453	0.416	2770	Q0	0.409	0.400	3370
	0.444	0.399			0.402	0.382	
	0.459	0.403			0.416	0.389	
	0.467	0.419			0.424	0.407	
M1	0.460	0.430	2770	Q1	0.414	0.414	3370
	0.453	0.416			0.409	0.400	
	0.467	0.419			0.424	0.407	
	0.473	0.432			0.430	0.421	
N0	0.438	0.412	2950	R0	0.392	0.391	3650
	0.429	0.394			0.387	0.374	
	0.444	0.399			0.402	0.382	
	0.453	0.416			0.409	0.400	
N1	0.444	0.426	2950	R1	0.414	0.414	3650
	0.438	0.412			0.409	0.400	
	0.453	0.416			0.392	0.391	
	0.460	0.430			0.397	0.406	
P0	0.424	0.407	3150	S0	0.392	0.391	3950
	0.416	0.389			0.387	0.374	
	0.429	0.394			0.374	0.366	
	0.438	0.412			0.378	0.382	
P1	0.430	0.421	3150	S1	0.397	0.406	3950
	0.424	0.407			0.392	0.391	
	0.438	0.412			0.378	0.382	
	0.444	0.426			0.382	0.397	

- Tolerance on each color bin (x , y) is ± 0.01

Note: Although several bins are outlined, product availability in a particular bin varies by production run and by product performance. Not all bins are available in all colors.

Dominant Wavelength Bin Structure

Color	Bin Code	Minimum Dominant Wavelength (nm)	Maximum Dominant Wavelength (nm)
Red	2	613.5	620.5
	4	620.5	631.0
Amber	2	587.0	589.5
	4	589.5	592.0
	6	592.0	594.5
	7	594.5	597.0
Green	A	515	520
	1	520	525
	2	525	530
	3	530	535
Blue	A	455	460
	1	460	465
	2	465	470
	3	470	475

- ProLight maintains a tolerance of ± 1 nm for dominant wavelength measurements.

Note: Although several bins are outlined, product availability in a particular bin varies by production run and by product performance. Not all bins are available in all colors.

Color Spectrum, $T_J = 25^\circ\text{C}$

1. White

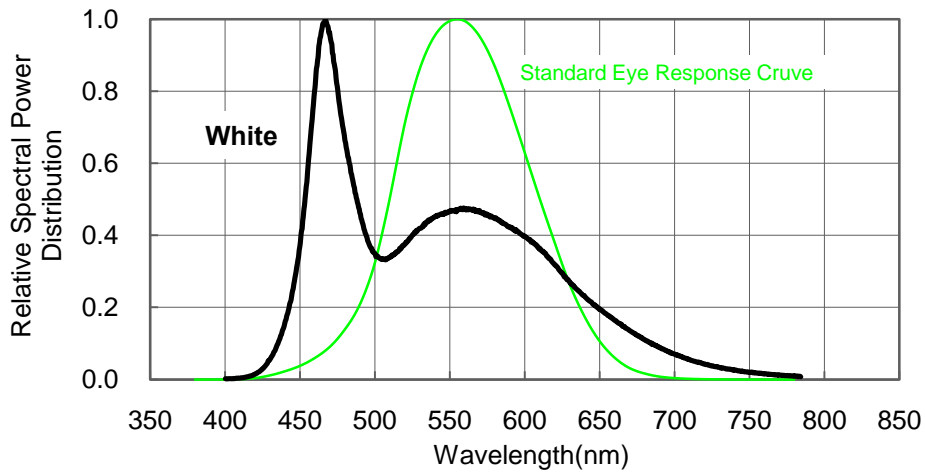

2. Warm White

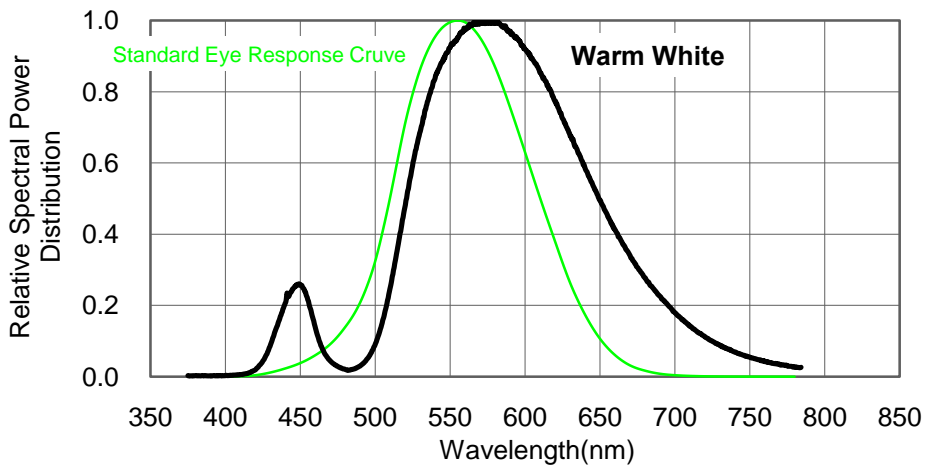

3. Blue 、 Green 、 Amber 、 Red

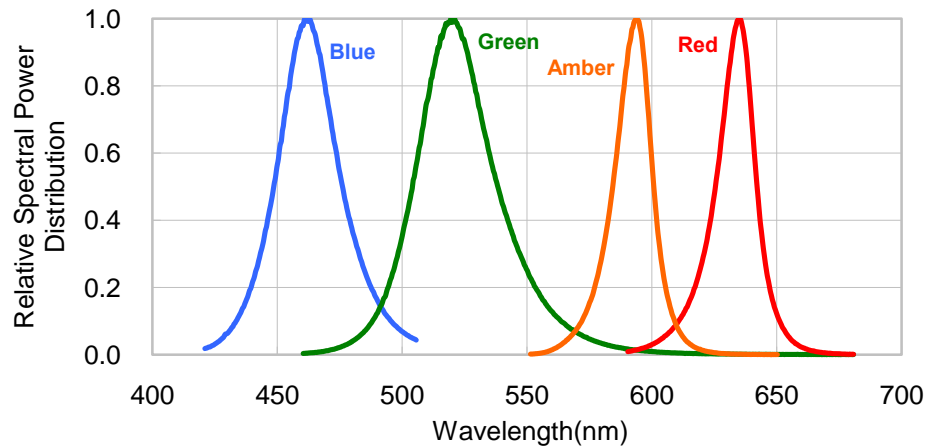

Light Output Characteristics

Relative Light Output vs. Junction Temperature at 700mA

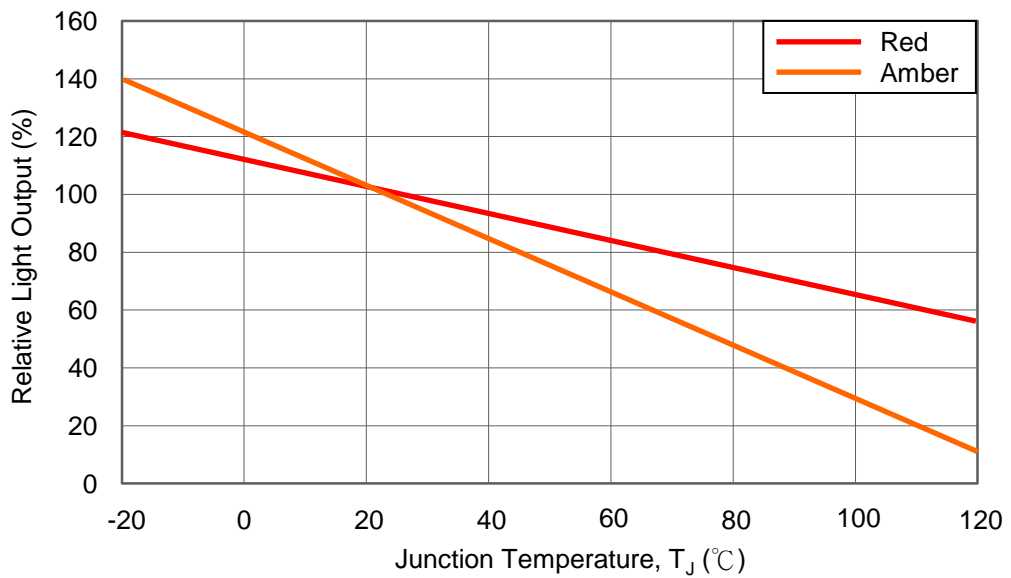
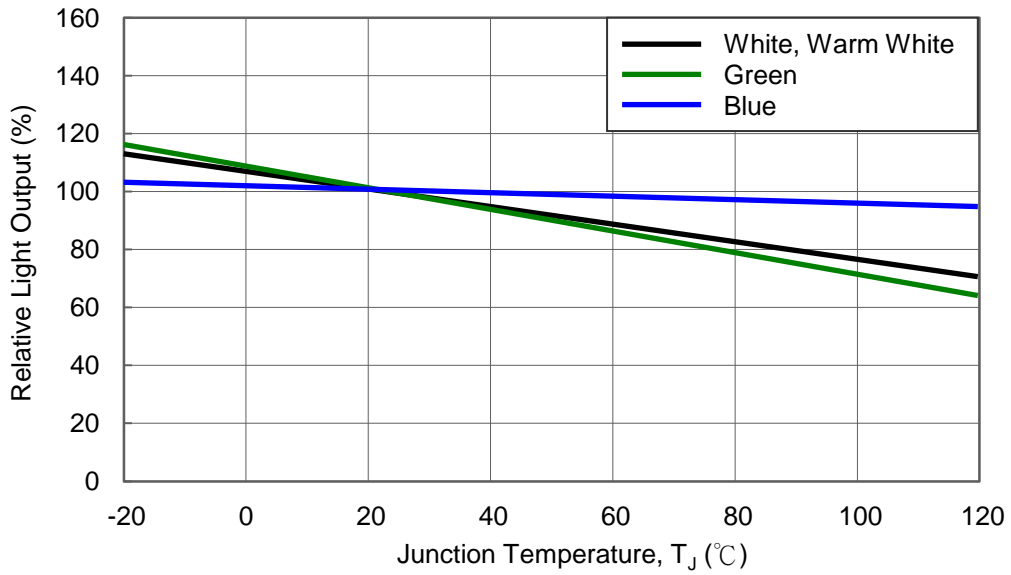

Forward Current Characteristics, $T_J = 25^\circ\text{C}$

1. Forward Voltage vs. Forward Current

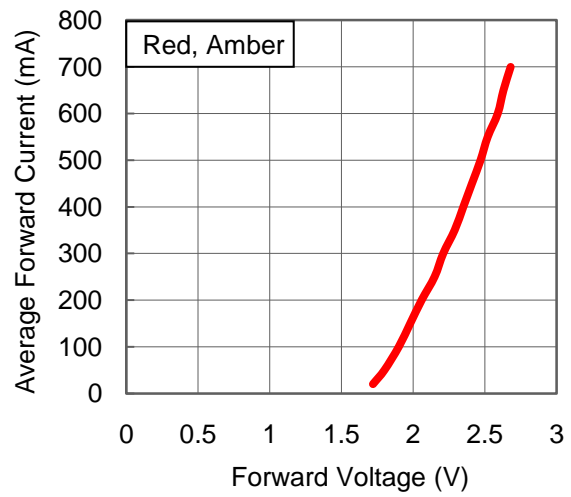
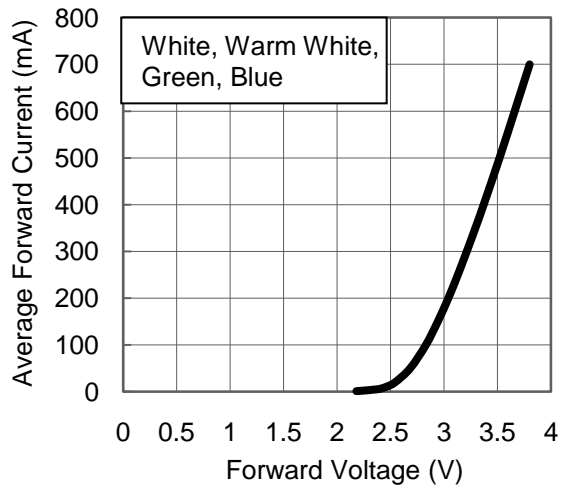

2. Forward Current vs. Normalized Relative Luminous Flux

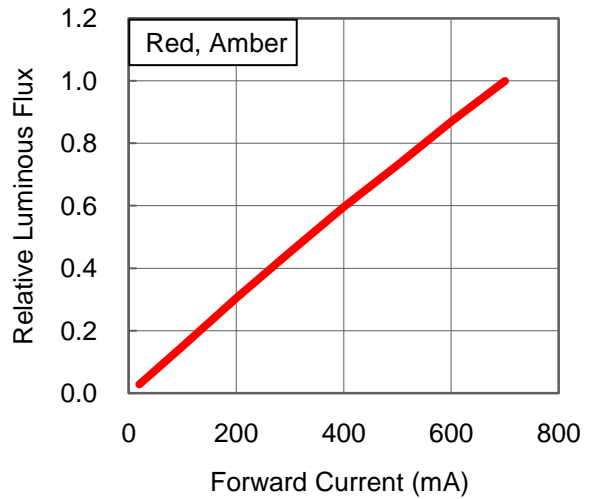
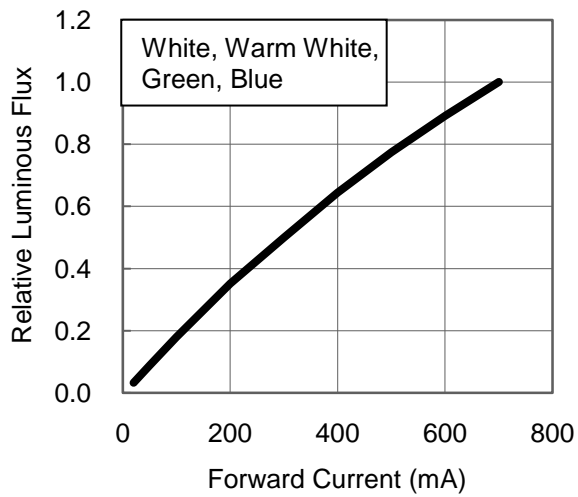

Ambient Temperature vs. Maximum Forward Current

1. White, Warm White, Green, Blue ($T_{JMAX} = 120^{\circ}C$, $T_{Ambient} = 75^{\circ}C$)

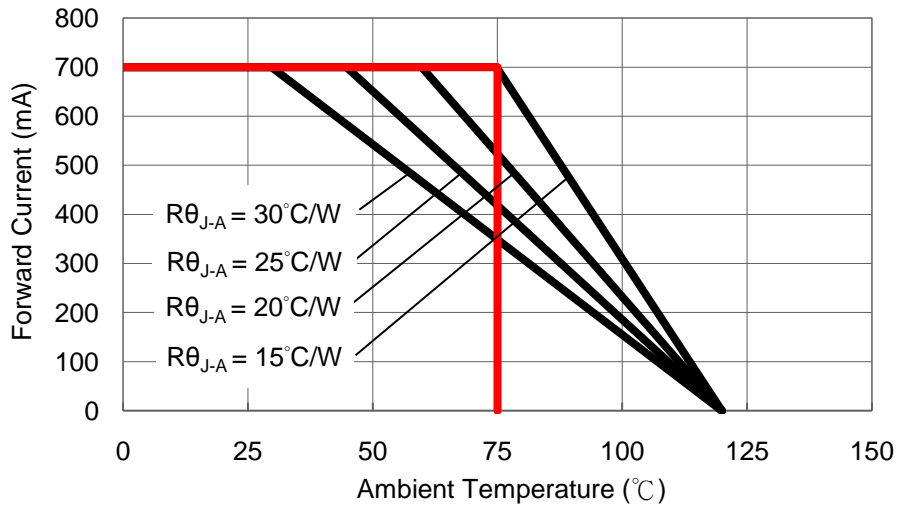

2. Red, Amber ($T_{JMAX} = 120^{\circ}C$, $T_{Ambient} = 75^{\circ}C$)

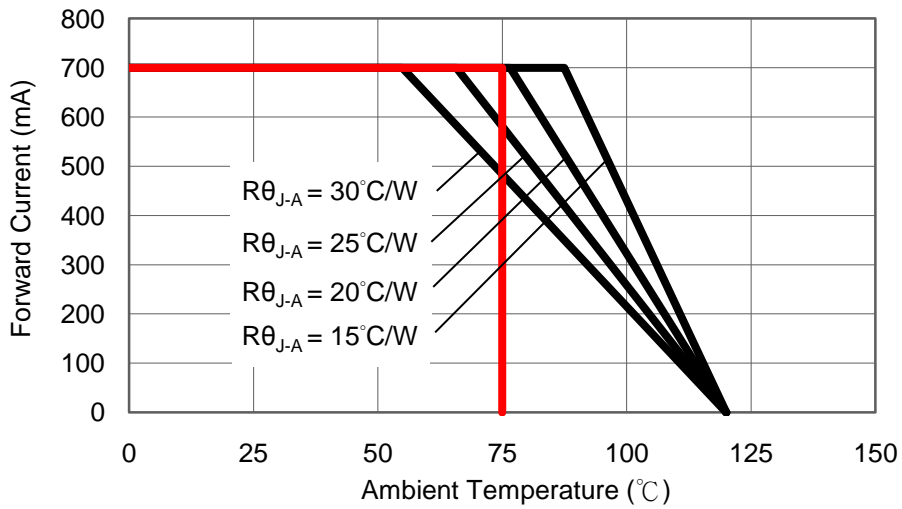

Typical Representative Spatial Radiation Pattern

Spot Radiation Pattern

